

GOSHORES 

**DOUBLE CYLINDER
E1530XS**

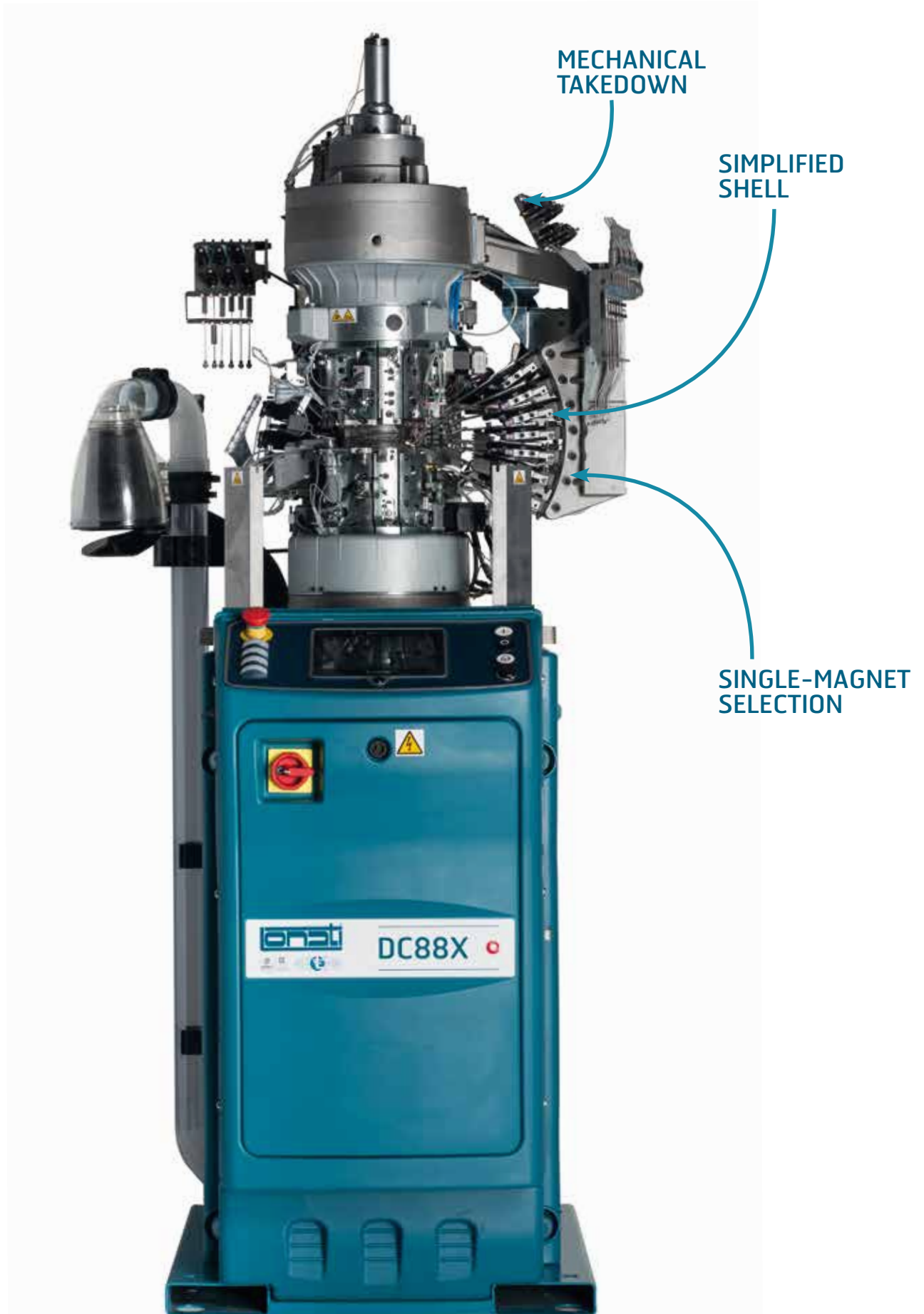

DOUBLE CYLINDER E1530XS





All images in this brochure are indicative and not binding.

DOUBLE CYLINDER E1530XS

Double cylinder 2 feeds machine for the production of shoe uppers in ribs, plain knit, links and links jacquard. Needle-needle single-magnet selection for different rib, links patterns and links jacquard. Shadow stripe and open-work knitting option. Brushless motor incorporated in the column with variable heel and toe reciprocating motion. 2 selection points instead of pickers and needle droppers. Machine available: 4" diameters (gauges from 8 to 11).

- Needle-needle single-magnet selection instead of pickers and needle droppers and links drums for different rib and links patterns.
- Simplified shell/skirt with less mobile cams
- Mechanical takedown
- Stitch cams with independent stepper motors
- Easier sinkers maintenance thanks to the rotating knitting head.
- Electronic full control of yarnfingers and of all functions.

MACHINE DIMENSIONS



Length cm 90 + yarn creel cm 32
Depth cm 104 + yarn creel cm 69
Height cm 260

MACHINE WEIGHT



Machine ca. 350 Kg
Yarn creel ca. 30 Kg

NOTE:

All data relating to outer appearance, performance, dimensions and weight are just as an indication.

DOUBLE CYLINDER

E1530XS

TECHNICAL DATA

MODEL	CYLINDER DIAMETER	GAUGE	NEEDLE THICKNESS
E1530XS	4"	from 8 to 11	0.9 mm

Above data are indicative and not binding.

STANDARD DEVICES

- Needle-needle single-magnet electronic selection system;
- Mechanical fabric take down;
- Multi-stiffening by means of stepper motor;
- High heel by means of single-magnetic selection;
- Sinker cap with internal lubrication;
- 6 pneumatic yarnfingers;
- 6-rod take-up device;
- Suction valve controlled with stepper motor;

OPTIONAL DEVICES

- Split device
- Pneumatic yarnfinger number 7
- First yarnfinger positioning at feeds 5,6 and 7
- Second yarnfinger positioning at feeds 2,3 and 4
- Prearrangement for YoYo feeders
- YoYo feeders
- Prearrangement for LGL Ecopower feeders
- LGL Ecopower feeders
- ISPY sensors
- Cassefils mechanical sensors
- Second elastic feeder
- Knots control
- Ethernet board
- Patterned shadow stripe knit
- Open-work

SUITABLE YARNS

The machine is designed to be used with the following yarns

- Natural fibers
- Syntetic yarn
- Elastic yarn

POSSIBLE KNITTING

The standard machine can perform the following knittings

- Plain knit
- Rib
- Links
- Links Jacquard

DOUBLE CYLINDER E1530XS

NUMBER OF COLORS

Number of colors

In jacquard 2 colors on the same course
Up to 5 colors on first feed
Up to 3 colors on second feed

PERFORMANCES

	4" CYLINDER DIAMETER
GAUGE	11 (needle thickness 0.9 mm)
KNITTING FEATURES	LINKS = 120 Rpm
	Rib and plain knit = 120 Rpm
	Reciprocated motion = 120 Rpm
	Jacquard = 120 Rpm

Above data are indicative and not binding.

GAUGES

Model	ø	GAUGE			
		8	9	10	11
1530XS	4"	96	108	120	132 144
		Needle thickness 0.9			

Above data are indicative and not binding.

DISCLAIMER:

For gauges lower or higher than those in the chart, their maximum speed must be reduced by 10-15%. Should you use staple fiber, maximum speed has to be detected each time according to the yarn and the item to be produced. For jacquard and Links jacquard, maximum speed has to be detected each time according to the pattern.

DOUBLE CYLINDER E1530XS

ELECTRIC POWER CONSUMPTION

With program for medium length shoe upper.

MACHINE MODEL	CONSUMPTION kWh
E1530XS	0.54

COMPRESSED AIR CONSUMPTION

Gauge pressure 6,5 bar, humidity 0% and dryer outlet temperature 18°C-21°C.

MACHINE MODEL	CYCLE TIME	CONSUMPTION FOR SHOE UPPER
E1530XS	3'13"	NI 120 - ft³ 4.2

SUCTION

Depression = Cylinder = 800 - 850 mm/H2O - **Flow**= 2 m³/min

NOISE LEVEL

Machine average noise level, suction included LpA=81.9 dB LwA=99 db

LUBRICANTS

Average consumption for 100 dozens= 330 gr. Lonati recommends: Kluber Madol 183 Supreme

GREASE

For seals, bearing etc Lonati recommends: Damping grease Nyogel 774F

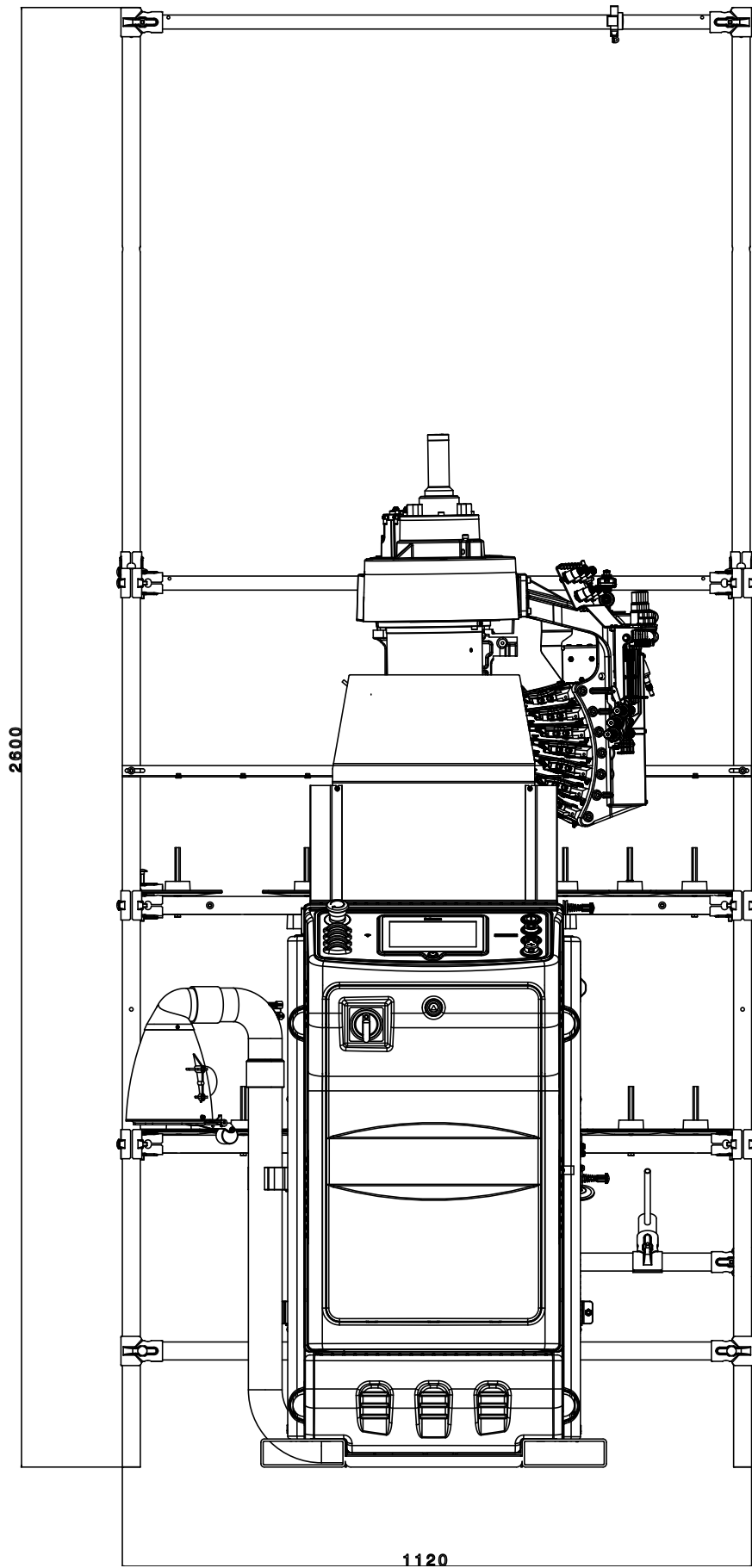

FRONT VIEW

Machine dimensions + 18 positions yarn creel.

NOTE:

The picture may show fittings and equipment that are supplied on demand and not.

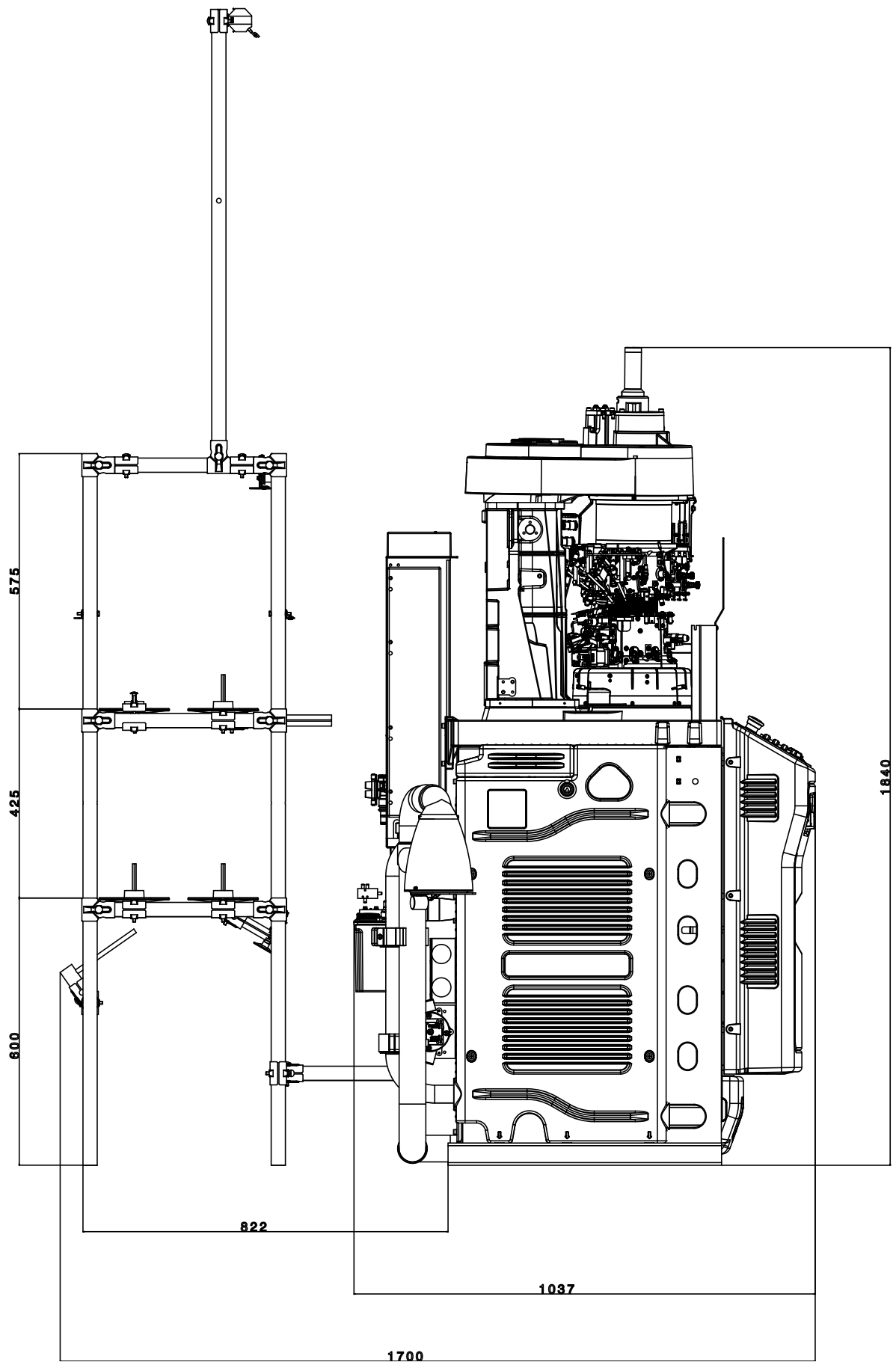

SIDE VIEW

Machine dimensions + 18 positions yarn creel.

NOTE:

The picture may show fittings and equipment that are supplied on demand and not.





LONATI SPA

Via Francesco Lonati, 3 | 25124 Brescia (Italy)
Tel. +39 030 23901 | Fax +39 030 2310024
C.F.: 01469680175 | P.iva: 02096730961
info@lonati.com - www.lonati.com